

DENON

CASSETTE TAPE DECK

DRR-M30

OPERATING INSTRUCTIONS

MODE D'EMPLOI

INSTRUCCIONES DE OPERACION

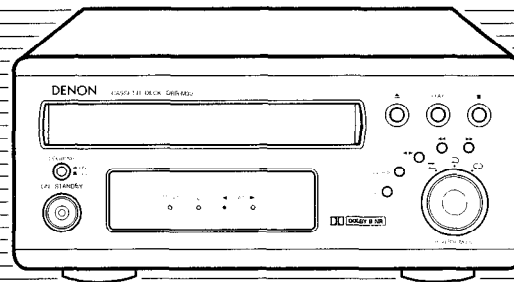

FOR ENGLISH READERS
POUR LES LECTEURS FRANCAIS
PARA LECTORES DE ESPAÑOL

PAGE 5 ~ PAGE 12
PAGE 13 ~ PAGE 20
PÁGINA 21 ~ PÁGINA 28

IMPORTANT TO SAFETY

WARNING:
TO PREVENT FIRE OR SHOCK HAZARD, DO NOT EXPOSE THIS APPLIANCE TO RAIN OR MOISTURE.

CAUTION:

- 1. Handle the power supply cord carefully**
 Do not damage or deform the power supply cord. If it is damaged or deformed, it may cause electric shock or malfunction when used. When removing from wall outlet, be sure to remove by holding the plug attachment and not by pulling the cord.
- 2. Do not open the top cover**
 In order to prevent electric shock, do not open the top cover. If problems occur, contact your DENON DEALER.
- 3. Do not place anything inside**
 Do not place metal objects or spill liquid inside the system. Electric shock or malfunction may result.

Please, record and retain the Model name and serial number of your set shown on the rating label.
 Model No. DRR-M30 Serial No. _____

CAUTION

RISK OF ELECTRIC SHOCK
DO NOT OPEN

CAUTION:
TO REDUCE THE RISK OF ELECTRIC SHOCK, DO NOT REMOVE COVER (OR BACK). NO USER-SERVICEABLE PARTS INSIDE. REFER SERVICING TO QUALIFIED SERVICE PERSONNEL.

The lightning flash with arrowhead symbol, within an equilateral triangle, is intended to alert the user to the presence of uninsulated "dangerous voltage" within the product's enclosure that may be of sufficient magnitude to constitute a risk of electric shock to persons.

The exclamation point within an equilateral triangle is intended to alert the user to the presence of important operating and maintenance (servicing) instructions in the literature accompanying the appliance.

• **FOR U.S.A. & CANADA MODEL ONLY**

CAUTION

TO PREVENT ELECTRIC SHOCK DO NOT USE THIS (POLARIZED) PLUG WITH AN EXTENSION CORD, RECEPTACLE OR OTHER OUTLET UNLESS THE BLADES CAN BE FULLY INSERTED TO PREVENT BLADE EXPOSURE.

• **POUR LES MODELES AMERICAINS ET CANADIENS UNIQUEMENT**

ATTENTION

POUR PREVENIR LES CHOCES ELECTRIQUES NE PAS UTILISER CETTE FICHE POLARISEE AVEC UN PROLONGATEUR UNE PRISE DE COURANT OU UNE AUTRE SORTIE DE COURANT, SAUF SI LES LAMES PEUVENT ETRE INSEREES A FOND SANS EN LAISSER AUCUNE PARTIE A DECOUVERT.

SAFETY INSTRUCTIONS

- 1. Read Instructions** – All the safety and operating instructions should be read before the appliance is operated.
- 2. Retain Instructions** – The safety and operating instructions should be retained for future reference.
- 3. Heed Warnings** – All warnings on the appliance and in the operating instructions should be adhered to.
- 4. Follow Instructions** – All operating and use instructions should be followed.
- 5. Water and Moisture** – The appliance should not be used near water – for example, near a bathtub, washbowl, kitchen sink, laundry tub, in a wet basement, or near a swimming pool, and the like.
- 6. Carts and Stands** – The appliance should be used only with a cart or stand that is recommended by the manufacturer.
- 6A. An appliance and cart combination should be moved with care.**
 Quick stops, excessive force, and uneven surfaces may cause the appliance and cart combination to overturn.
- 7. Wall or Ceiling Mounting** – The appliance should be mounted to a wall or ceiling only as recommended by the manufacturer.
- 8. Ventilation** – The appliance should be situated so that its location or position does not interfere with its proper ventilation. For example, the appliance should not be situated on a bed, sofa, rug, or similar surface that may block the ventilation openings, or, placed in a built-in installation, such as a bookcase or cabinet that may impede the flow of air through the ventilation openings.
- 9. Heat** – The appliance should be situated away from heat sources such as radiators, heat registers, stoves, or other appliances (including amplifiers) that produce heat.
- 10. Power Sources** – The appliance should be connected to a power supply only of the type described in the operating instructions or as marked on the appliance.
- 11. Grounding or Polarization** – Precautions should be taken so that the grounding or polarization means of an appliance is not defeated.
- 12. Power-Cord Protection** – Power-supply cords should be routed so that they are not likely to be walked on or pinched by items placed upon or against them, paying particular attention to cords at plugs, convenience receptacles, and the point where they exit from the appliance.
- 14. Cleaning** – The appliance should be cleaned only as recommended by the manufacturer.
- 15. Power Lines** – An outdoor antenna should be located away from power lines.
- 16. Outdoor Antenna Grounding** – If an outside antenna is connected to the receiver, be sure the antenna system is grounded so as to provide some protection against voltage surges and built-up static charges. Article 810 of the National Electrical Code, ANSI/NFPA 70, provides information with regard to proper grounding of the mast and supporting structure, grounding of the lead-in wire to an antenna-discharge unit, size of grounding conductors, location of antenna-discharge unit, connection to grounding electrodes, and requirements for the grounding electrode. See Figure A.
- 17. Nonuse Periods** – The power cord of the appliance should be unplugged from the outlet when left unused for a long period of time.
- 18. Object and Liquid Entry** – Care should be taken so that objects do not fall and liquids are not spilled into the enclosure through openings.
- 19. Damage Requiring Service** – The appliance should be serviced by qualified service personnel when:
 - A. The power-supply cord or the plug has been damaged; or**
 - B. Objects have fallen, or liquid has been spilled into the appliance; or**
 - C. The appliance has been exposed to rain; or**
 - D. The appliance does not appear to operate normally or exhibits a marked change in performance; or**
 - E. The appliance has been dropped, or the enclosure damaged.**
- 20. Servicing** – The user should not attempt to service the appliance beyond that described in the operating instructions. All other servicing should be referred to qualified service personnel.

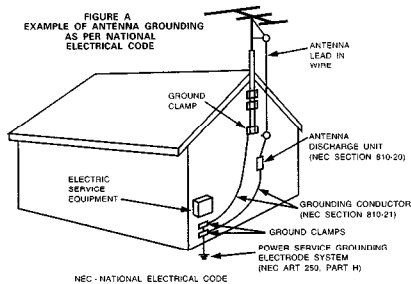



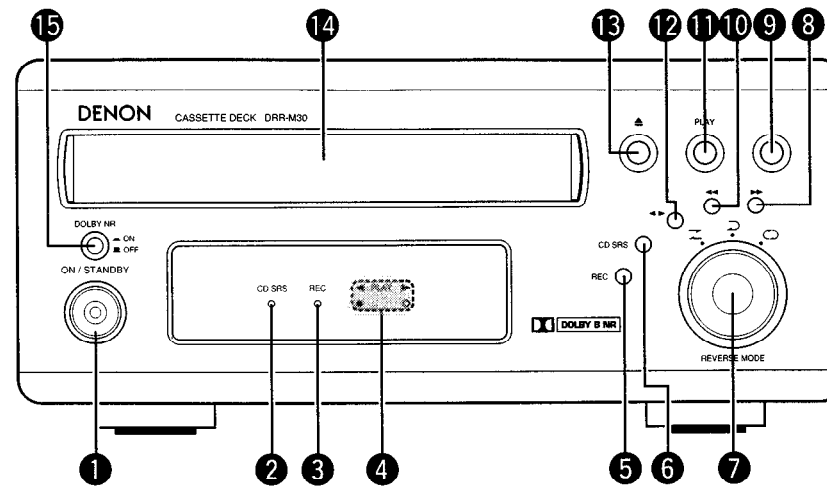

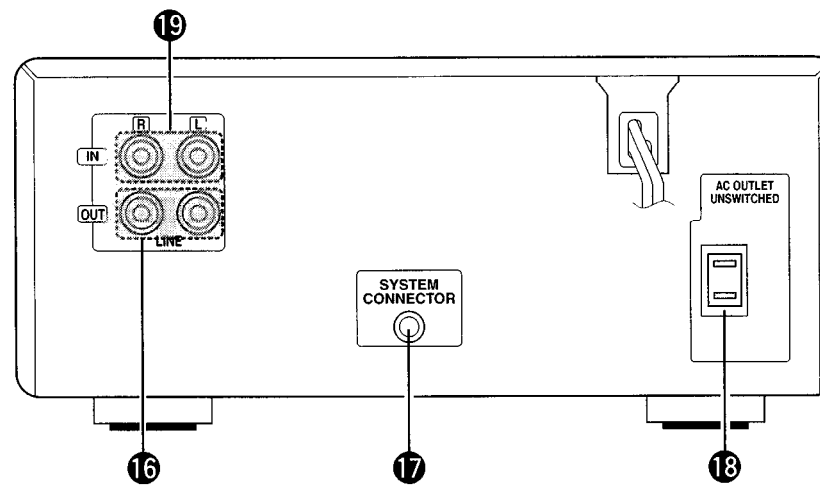

FRONT PANEL
PANNEAU AVANT
TABLERO FRONTAL

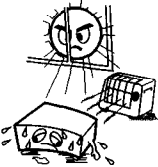

REAR PANEL
PANNEAU ARRIERE
PANEL TRASERO

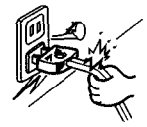
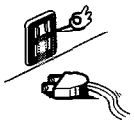

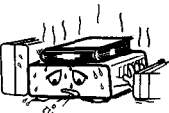
NOTE ON USE / OBSERVATIONS RELATIVES A L'UTILISATION / NOTAS SOBRE EL USO

 <ul style="list-style-type: none"> • Avoid high temperatures. Allow for sufficient heat dispersion when installed on a rack. • Eviter des températures élevées Tenir compte d'une dispersion de chaleur suffisante lors de l'installation sur une étagère. • Evite altas temperaturas. Permite la suficiente dispersión del calor cuando está instalado en la consola. 	 <ul style="list-style-type: none"> • Keep the set free from moisture, water, and dust. • Protéger l'appareil contre l'humidité, l'eau et la poussière. • Mantenga el equipo libre de humedad, agua y polvo. 	 <ul style="list-style-type: none"> • Do not let foreign objects in the set. • Ne pas laisser des objets étrangers dans l'appareil. • No deje objetos extraños dentro del equipo.
 <ul style="list-style-type: none"> • Handle the power cord carefully. Hold the plug when unplugging the cord. • Manipuler le cordon d'alimentation avec précaution. Tenir la prise lors du débranchement du cordon. • Maneje el cordón de energía con cuidado. Sostenga el enchufe cuando desconecte el cordón de energía. 	 <ul style="list-style-type: none"> • Unplug the power cord when not using the set for long periods of time. • Débrancher le cordon d'alimentation lorsque l'appareil n'est pas utilisé pendant de longues périodes. • Desconecte el cordón de energía cuando no utilice el equipo por mucho tiempo. 	 <ul style="list-style-type: none"> • Do not let insecticides, benzene, and thinner come in contact with the set. • Ne pas mettre en contact des insecticides, du benzène et un diluant avec l'appareil. • No permita el contacto de insecticidas, gasolina y diluyentes con el equipo.
	 <p>* (For sets with ventilation holes)</p> <ul style="list-style-type: none"> • Do not obstruct the ventilation holes. • Ne pas obstruer les trous d'aération. • No obstruya los orificios de ventilación. 	 <ul style="list-style-type: none"> • Never disassemble or modify the set in any way. • Ne jamais démonter ou modifier l'appareil d'une manière ou d'une autre. • Nunca desarme o modifique el equipo de ninguna manera.

CONTENTS

1 Main Features5	7 Recording Cassette Tapes10
2 Before Using5	8 System Functions11
3 Part Names and Functions5	9 Other Information12
4 Connections6	10 Specifications12
5 Before Recording and Playing Tapes7	11 Troubleshooting12
6 Playing Cassette Tapes9	

Check that the following parts are included in the package aside from the main unit:

(1) Operating instructions1	(3) System connector cable1
(2) RCA pin-plug cord2	(4) Service station list1

1 MAIN FEATURES

1. Horizontal loading for stable travel

The horizontal loading mechanism used on the DRR-M30 is the ideal type of tray for the rotating parts, the most important part of the cassette deck. Mounting the deck mechanism horizontally lessens vibration of the flywheel in the thrust direction and reduces modulation noise.

2. Various editing and playback functions

- Auto bias mechanism for recording and playing for long periods of time.
- Auto tape selector for automatically identifying the tape type.
- Music search for choosing selections up to 16 selections away in either direction.

3. Convenient system functions

The DRR-M30 is equipped for system functions allowing easy synchronized recording, timer recording/playback and auto function and auto power on operations when used in combination with the D-M30 series. In addition, system units can be operated using the system remote control unit included with the CD receiver unit (UD-M30/M50).

2 BEFORE USING

Read the following before using the system.

- **Before turning on the power**
Check again that all connections are correct and that there are no problems with the connection cords. Be sure to unplug the power cord before connecting or disconnecting the connection cords.
- Humming may be produced if this system is set near a TV or other audio equipment. If this happens, try changing the position of the equipment or the connection cords.
- **Moving the system**
To prevent short-circuits or damage to the connection cords, always unplug the power cord and disconnect all connection cords to other audio equipment.

- **Condensation (dew)**
Water droplets may condense on internal operating parts if the set is brought into a heated room from the cold outdoors or when the room is heated rapidly. If this happens, the set may not operate properly.
- **Should condensation occur**
The condensation will evaporate in one hour or less, at which time the system will function normally.
- Note that some of the illustrations used for explanations in this manual may differ from the actual system.

3 PART NAMES AND FUNCTIONS

- 1 **Power operation switch (ON/STANDBY)**
Press this once to turn the cassette deck's power on. Press again to set the cassette deck to the standby mode.
The LED color changes as follows, according to the condition:
During power ON: green
During STANDBY: red
- 2 **CD SRS indicator**
This lights during system synchronized recording of a CD.
- 3 **REC indicator**
This lights during recording.
- 4 **PLAY mode indicator**
The direction of tape travel and play mode are displayed here.
- 5 **REC button**
This button is used when recording and when creating blank spaces between selections. If only the REC button is pressed, the recording pause mode is set.
For details, refer to page 10.
NOTE:
• If the play button on the CD Receiver (UD-M30/M50) is pressed during the recording pause mode when connected with other components of the D-M30 series, recording of the CD begins automatically.
- 6 **CD SRS (Synchronized Recording System) button**
Use this button for synchronized recording of CDs.
For details, refer to page 11.
- 7 **REVERSE MODE selector switch**
Use this to select the direction of tape travel.
For details refer to page 8.
- 8 **▶▶ (fast-forward) button**
Press this button to fast-forward the front side of the tape. (The back side of the tape is rewind.) Also use this button to search for the beginning of the following selection when playing in the forward (▶) direction, or to search for the beginning of the current selection when playing in the reverse (◀) direction.
- 9 **■ (stop) button**
Press this button while the tape is moving to stop the tape.

- 10 **◀◀ (rewind) button**
Press this button to rewind the front side of the tape. (The back side of the tape is fast-forwarded.) Also use this button to search for the beginning of the current selection when playing in the forward (▶) direction, or to search for the beginning of the following selection when playing in the reverse (◀) direction.
- 11 **PLAY button**
Press this button to play the tape. If this button is pressed in the standby mode, the power of the cassette deck and CD receiver automatically turns on and playback begins. (AUTO ON function)
- 12 **◀▶ (direction) button**
Press to reverse the direction of tape playback or recording.
- 13 **▲ OPEN/CLOSE button**
Press this to open and close the cassette tray.
When pressed in the standby mode, the cassette deck's power turns on.
- 14 **Cassette tray**
The cassette tray opens out when the OPEN/CLOSE button is pressed. Load the cassette tape with the side on which the tape is exposed facing away from you. To close the cassette tray, press the OPEN/CLOSE button again. For details, refer to page 7.
- 15 **DOLBY NR mode selector switch**
Use this to select the Dolby NR mode (ON or OFF).
When playing a tape, set the Dolby NR mode to the same mode as when the tape was recorded.
- 16 **LINE OUT (analog output) jacks**
When these jacks are connected to the tape input (TAPE IN) jacks on the CD receiver, the sound from the DRR-M30 can be heard through the speakers connected to them.
- 17 **SYSTEM CONNECTOR**
When using with the D-M30 series, connect this connector to the system connector on another unit using the included system connector cable.
- 18 **AC OUTLET**
Use this when using the DRR-M30 with the D-M30 series. For connections, refer to "4 CONNECTIONS" (60 W max.)
- 19 **LINE IN (analog input) jacks**
When this jacks are connected to the tape output (TAPE OUT) jacks on the CD receiver, the sound of other components connected to them can be recorded on the DRR-M30.

4 CONNECTIONS

NOTE:
This system includes digital circuitry which may cause interference such as color blotching or changes in the color on TVs. If this happens, move the system and the TV as far apart as possible.

CAUTION:
Whenever the power operation switch is in the STANDBY position, the unit is still connected on AC line voltage. Please be sure to unplug the cord when you leave home for, say, a vacation.

NOTE:
The following illustration shows the connections when the unit is to be used in combination with the UD-M30. When the unit is to be used in combination with the UD-M50, please refer to the respective instruction manual which is supplied with the equipment.

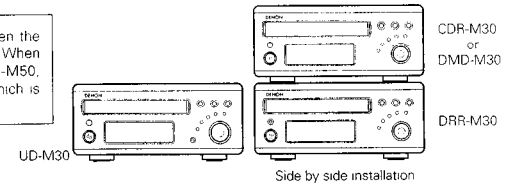

Install the sets as shown in one of these diagrams. In either case, be sure that the CD receiver's ventilation holes are not obstructed.

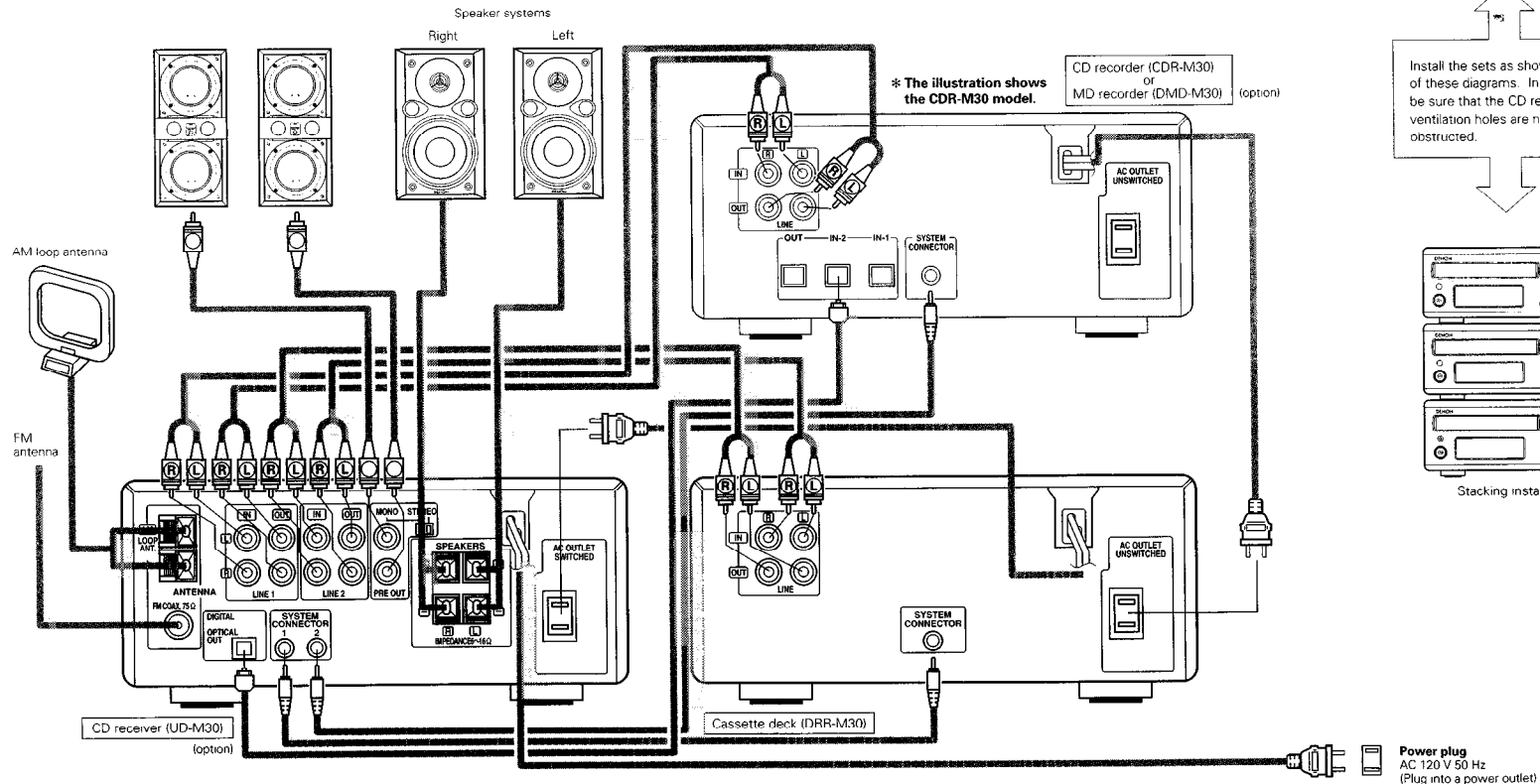
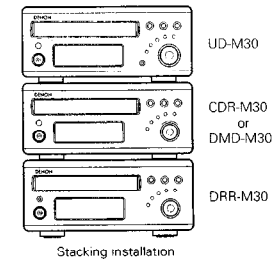

System operations

System operations, such as the timer and the auto on functions, as well as remote control operations cannot be performed unless all the RCA pin-plug cords and system connector cords are connected between the units, so be sure to make all the connections properly as shown in the diagram. Also, disconnecting system connectors while the system is operating may result in malfunction. Be sure to turn off, and unplug the power cord before changing connections.

NOTES:

- Do not plug the power cord into the power outlet until all connections are completed. Be sure to interconnect the channels (L to L (white) and R to R (red)) properly, as shown on the diagram.
- Insert the plugs securely. Incomplete connections may result in noise.
- After unplugging the power cord, wait about 5 seconds before plugging it back in.
- Note that setting the connection cords (pin-plug cords) next to the power cords may result in humming or other noise.

5 BEFORE RECORDING AND PLAYING TAPES

About Cassette Tapes

■ Cautions on handling cassette tapes

- C-120 cassette tapes
C-120 (120-minute) cassettes use very thin tape which can easily get caught on the capstans and pinch rollers. We recommend not using C-120 tapes.
- Tape slack
If the tape is slack, it may get caught in the mechanism and damaged. Take up any slack in the tape with a pencil, etc., before loading the cassette.

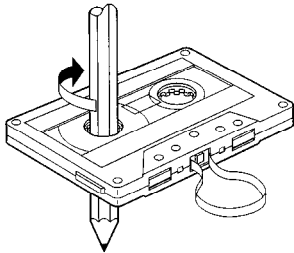

■ Preventing accidental erasure

- Cassette tapes have tabs for preventing accidental erasure. Use a screwdriver, etc., to break off the tabs to prevent recordings from being accidentally erased.
- To record on a tape whose tabs have been broken, place a piece of cellophane tape, etc., over the tab holes.

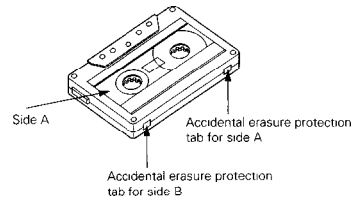

■ Notes on storing cassette tapes

- Avoid placing cassette tapes in the following types of places:
 - Hot or humid places
 - Dusty places
 - Places exposed to direct sunlight
 - Near magnetic sources (TVs, speakers, etc.)
- Store cassette tapes in cases with stoppers to prevent the tape from getting slack.

Auto Tape Selector Mechanism

The DRR-M30 is equipped with an auto tape selector mechanism which uses the detection holes in the cassette halves to detect the type of tape and automatically set the most appropriate recording bias and equalization for that type of tape.

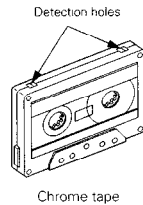

NOTE:

The metal tapes can only be used for playback.

Loading and Unloading Cassette Tape

NOTE:

Load cassette tapes with the side on which the tape is exposed facing the set. Loading them the other way may result in damage.

■ Loading

- ① Press the OPEN/CLOSE button. The cassette tray opens.
- ② Load the cassette tape in the cassette tray as shown on the diagram below, with the side on which the tape is exposed facing inside.
- ③ Press the OPEN/CLOSE button to close the cassette tray.

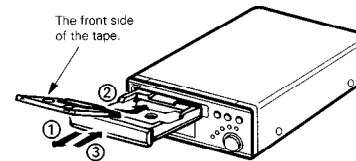

■ Unloading

- ① Press the OPEN/CLOSE button. The cassette tray opens.
- ② Remove the tape.

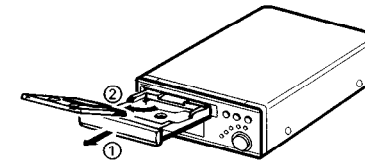

Check the following before recording or playing cassette tapes:

1. Are the heads dirty? The sound quality will be poor if the heads are dirty. Refer to page 12.
2. Are the accidental erasure protection tabs broken off? ... Recording is not possible if the accidental erasure protection tabs on the top of the cassette are broken off. Refer to page 7.

Using the Auto Reverse Function

This deck is equipped with an auto reverse function, so the tape can be played or recorded on both sides or played continuously without removing the cassette.

■ **Direction of tape travel**

Before playback or recording with this unit, press the direction button (◀▶) and select the forward direction (▶) or the reverse direction (◀), then press the PLAY button. A press of the direction button (◀▶) during recording or playback will cause the direction to switch.

The front side is the side facing up when the tape is loaded in the cassette tray.

■ **Reverse mode**

There are three reverse modes, as described below. For instructions on switching between them, refer to page 8, 9.

• **Single-sided recording/playback mode (↔)**

Use this to record or play only the front or back side. (The stop mode is set automatically when the end of that side of the tape is reached.)

• **Double-sided recording/playback mode (↻)**

• In this mode, when the end of the front side of the tape is reached during recording or playback, the tape automatically switches to the back side and playback or recording continues. (The stop mode is set automatically when the end of the tape on the back side is reached.)

• **Continuous play mode (⌂)**

In this mode, playback continues until the stop button is pressed.

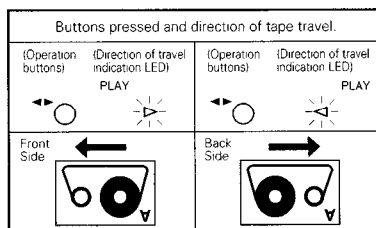

* When started from the back side, only the back side is recorded or played.



* During recording, the deck automatically operates in the same way as for the double-sided recording/playback mode (↻).

6 PLAYING CASSETTE TAPES (single-sided, double-sided and continuous playback)

Cassette deck (DRR-M30)

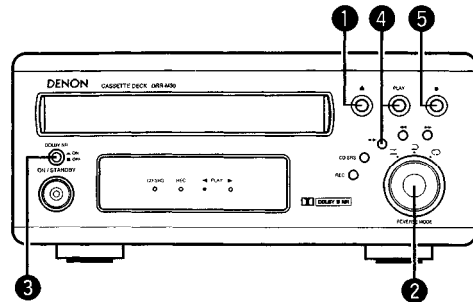

The mark indicates operations which can also be performed on the remote control unit. (Refer to page 11.)

<p>1</p> <p>Press the button and load a recorded tape in the cassette tray. Refer to page 7.</p>	<p>The front side.</p>
<p>2</p> <p>Slide the REVERSE MODE selector switch. Refer to page 8.</p>	<p>Single-sided Double-sided Continuous</p> <p>REVERSE MODE</p>
<p>3</p> <p>Turn the DOLBY NR mode selector switch.</p>	<p>DOLBY NR ON OFF</p> <p>When playing tapes recorded with Dolby NR, set the Dolby mode to the same mode (ON or OFF) as when the tape was recorded.</p>
<p>4</p> <p>Press the direction () button to change the direction of playback. Press the PLAY button. The PLAY mode indicator flashes slowly.</p>	<p>PLAY</p> <p>Playback begins in the direction of PLAY mode indicator.</p>
<p>5</p> <p>To stop playback, press the (stop) button.</p>	

Fast-forwarding and rewinding

<p>1</p> <p>When listening to the front side: (when is lit)</p>	<p>Press the (stop) button.</p> <p>Direction of travel</p> <p>To scan backward To scan forward</p>
<p>2</p> <p>When listening to the back side: (when is lit)</p>	<p>Press the (stop) button.</p> <p>Direction of travel</p> <p>To scan forward To scan backward</p>

Using the Music Search Function (automatically finding the beginning of selections)

- Use this function to move back to the beginning of the current selection or forward to the beginning of the following selection.
- This function can also be used to skip over selections (up to 16 selections in either direction).

<p>1</p> <p>When listening to the front side: (when is lit) The PLAY mode indicator flashes rapidly.</p>	<p>To move to the beginning of the current selection: Press once.</p> <p>To move back five selections: Press six times.</p> <p>To move to the beginning of the following selection: Press once.</p> <p>To move ahead five selections: Press five times.</p>
<p>2</p> <p>When listening to the back side: (when is lit) The PLAY mode indicator flashes rapidly.</p>	<p>To listen to the following track: Press once.</p> <p>To listen to the track five tracks forward: Press five times.</p> <p>To return to the beginning of the current track: Press once.</p> <p>To return to the track five tracks before: Press six times.</p>

- To fast-forward or rewind the tape, first press the (stop) button, then press the or .
- The music search function will only work if there are blank sections of at least 4 seconds between selections.

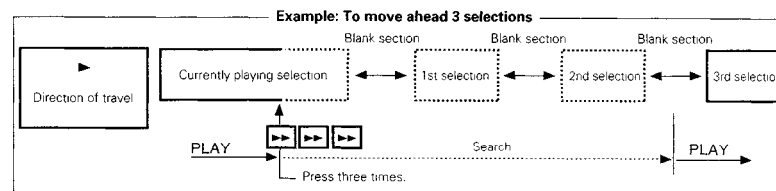

7 RECORDING CASSETTE TAPES

Cassette deck (DRR-M30)

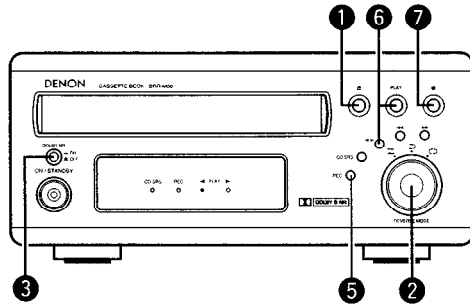

- Before recording on a cassette tape, check that its accidental erasure protection tabs are intact. Recording is not possible if the tabs are broken off.
- For connections, refer to "[4] CONNECTIONS" on page 6.

The [R] mark indicates operations which can also be performed on the remote control unit. (Refer to page 11.)

<p>1</p> <p>Press the OPEN/CLOSE button and load the tape onto which you want to record in the cassette tray. Refer to page 7.</p>	<p>The front side.</p>
<p>2</p> <p>Slide the REVERSE MODE selector switch to the , or . Refer to page 8.</p> <p>NOTE: If the reverse mode is set to continuous () during recording, the double-sided mode () is set automatically, and recording stops automatically once both sides have been recorded.</p>	<p>Single-sided</p> <p>Double-sided</p> <p>Continuous</p> <p>REVERSE MODE</p>
<p>3</p> <p>Turn the DOLBY NR mode selector switch.</p>	<p>DOLBY NR</p> <p>ON</p> <p>OFF</p> <p>To record in Dolby NR, set to "ON" or "OFF"</p>

	NORMAL RECORDING	SYNCHRONIZED RECORDING	
	To record the radio	To record from the component connected to the AUX terminals (The videodeck or LD Player etc.)	To record from a CD recorder (CDR-M30) or MD recorder (DMD-M30)
4	<p>Press the BAND selector button of the CD receiver.</p> <p>Tune in the station to be recorded.</p> <p>[R]</p>	<p>Press the FUNCTION button on the CD receiver to select "AUX"</p> <p>[R]</p>	<p>Load the disc in the MD (CD) recorder.</p>
5	<p>Press the REC button.</p> <p>[R]</p>	<p>The recording pause mode is set and the REC indicator is lit.</p>	
6	<p>Press the direction () button to change the direction of recording. Press the PLAY button. (Recording starts.)</p> <p>Starting playback on the video deck or LD player.</p> <p>[R]</p>	<p>Press the MD (CD) recorder's play button to start playback. (Recording starts automatically)</p> <p>(CDR-M30 or DMD-M30)</p> <p>[R]</p>	
7	<p>To stop recording, press the (stop) button.</p> <p>[R]</p>		

- Press the REC button again while in the recording pause mode to set the recording mute mode for approximately 5 seconds, after which the mode returns to the recording pause mode.
- The recording pause mode is set when the REC button is pressed for less than 0.5 seconds while in the recording mode. If it is pressed for over 0.5 seconds while in the recording mode, the recording mute mode is set for approximately 5 seconds, after which the recording pause mode is once again set. Press the (stop) button to cancel the recording pause mode.

8 SYSTEM FUNCTIONS

Operating the DRR-M30 is even easier when it is connected to the D-M30 series.
(For connections, refer to "4 CONNECTIONS" on page 6.)

System Remote Control

- The DRR-M30 does not come with a remote control unit. When using it with the D-M30 series, it can be operated with the remote control unit included with the CD receiver unit (UD-M30/M50).
- When the system is connected, the remote control signals of all units are received by the sensor on the CD receiver unit.

1. Auto on function

- When the PLAY button or OPEN/CLOSE button on the cassette tape deck is pressed while the DRR-M30's power is to the standby mode, the power automatically turns on and the play or the tray open is performed.

2. Synchronized recording (when the D-M30 series are connected)

(1) CD or MD → Cassette Tape

Set the DRR-M30 to the recording pause mode, then press the PLAY button on the CD receiver (UD-M30/M50), CD recorder (CDR-M30) or MD recorder (DMD-M30).

- Recording starts automatically.

(2) Cassette Tape → CD recorder or MD recorder

Set the CD recorder (CDR-M30) or MD recorder (DMD-M30) to the recording pause mode and press the PLAY button on the DRR-M30.

- Recording starts automatically.

3. Synchronized recording of CDs (when the D-M30 series are connected)

CDs can be recorded easily.

With the UD-M30/M50
(* The illustration shows the UD-M30 model.)

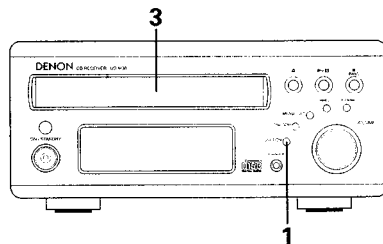

DRR-M30

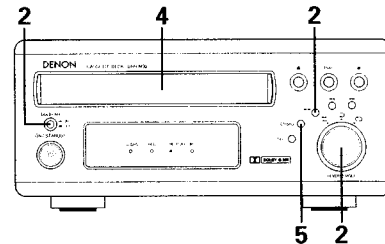

1	Use the FUNCTION (Input) select button on the UD-M30/M50 to set the function to "CD"
2	Set the tape travel direction, the reverse mode and the Dolby NR mode.
3	Load the CD in the UD-M30/M50.
4	Load the cassette tape on which you want to record into the DRR-M30.
5	Press the CD SRS button. • Recording starts automatically.

- The CD SRS function will not work if the UD-M30/M50 is set to the program mode.

4. Timer functions (when the D-M30 series are connected)

The timer can be used to play sources or record radio broadcasts ("AIR CHECK") at set times.

(1) Playing a cassette tape deck with the timer

With the UD-M30/M50
(* The illustration shows the UD-M30 model.)

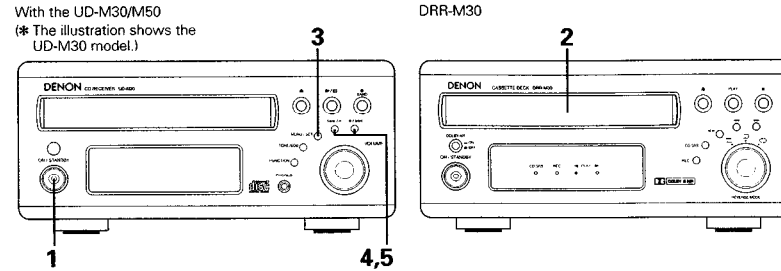

- To select and set the type of timer operations between following step 3 and 4, refer to "USING TIMER" in the UD-M30/M50 operating manual.

1	Press the Power operation switch on the CD receiver unit to turn on the system's power.
2	Load the cassette tape you want to play with the timer into the DRR-M30.
3	Press the MENU/SET button to display "TIMER"
4	Use the preset buttons (+ and -) to select the timer mode.
5	Use the preset buttons (+ and -) to select the CD receiver "TAPE" mode.
6	For subsequent operations, refer to "USING THE TIMER" in the UD-M30/M50 operating manual.

(2) Unattended recording of radio programs (AIR CHECK)

With the UD-M30/M50
(* The illustration shows the UD-M30 model.)

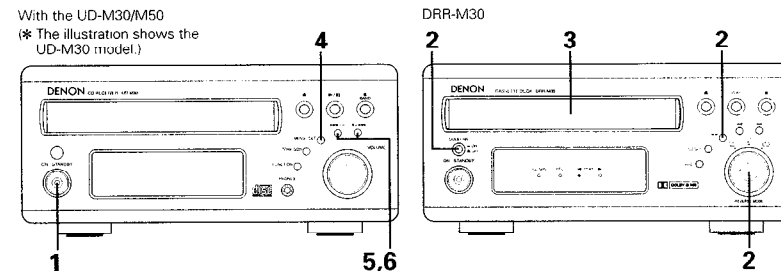

- To select and set the type of timer operations between following step 4 and 5, refer to "USING TIMER" in the UD-M30/M50 operating manual.

1	Press the Power operation switch on the CD receiver unit to turn on the system's power.
2	Set the tape travel direction, the reverse mode and the Dolby NR mode.
3	Load the cassette tape on which you want to record into the DRR-M30.
4	Press the MENU/SET button to display "TIMER"
5	Use the preset buttons (+ and -) to select the timer mode.
6	Use the preset buttons (+ and -) to select the CD receiver "TU > TAPE" mode.
7	For subsequent operations, refer to "USING THE TIMER" in the UD-M30/M50 operating manual.

9 OTHER INFORMATION

Cleaning the Heads

- If the cassette deck's heads are dirty, tapes cannot be played or recorded with good sound quality.
- To take full advantage of all the performance this cassette deck has to offer and ensure good quality sound, clean the heads periodically after approximately 10 hours of use, using a commercially available cleaning cassette.

NOTE:
Some commercially available cleaning cassettes are highly abrasive and may damage the heads. Avoid using such cleaning cassettes.

Demagnetizing the Heads

- The heads become magnetized after they have been used for an extended period of time or if they are exposed to a magnetic object. This results in noise or a loss of the treble sound.
- If the heads are magnetized, use a commercially available cassette-type head demagnetizer to demagnetize them.

10 SPECIFICATIONS

Type:	Horizontal 4-track 2-channel stereo auto reverse cassette deck
Heads:	1 hard permalloy recording/playback head 1 double-gap ferrite erasing head
Tape speed:	4.75 cm/s
Included circuits:	Dolby B NR
Usable tapes:	Normal, chrome
Power supply:	AC 120 V, 50 Hz
Power consumption:	10 W
Maximum external dimensions:	210 (W) x 95 (H) x 318 (D) mm (including feet, controls and terminals)
Mass:	3 kg

* Maximum dimensions include controls, jacks, and covers.
(W) = width, (H) = height, (D) = depth

- For improvement purposes, specifications and functions are subject to change without advanced notice.

■ Dolby noise reduction manufactured under license from Dolby Laboratories Licensing Corporation.

■ "DOLBY" and the double-D symbol  are trademarks of Dolby Laboratories Licensing Corporation.

11 TROUBLESHOOTING

Check the following once more before assuming there is a problem with the system.

1. Are connections proper ?

2. Is the system being operated as explained in the operating instructions ?

If the system does not seem to be operating properly, check as shown on the table below. If none of these checks apply to the problem, the system may be malfunctioning. Disconnect the power cord immediately and contact your store of purchase.

Symptom	Cause	Countermeasure	Page
Recording does not start when REC button is pressed.	<ul style="list-style-type: none"> • No cassette tape is loaded. • Accidental erasure protection tabs are broken off. 	<ul style="list-style-type: none"> • Load a cassette tape. • Cover the tab holes with cellophane tape. 	7 7
Sound is broken or no sound is produced during recording and playback.	<ul style="list-style-type: none"> • Heads are dirty. • Cassette tape is defective. 	<ul style="list-style-type: none"> • Clean the heads. • Replace the cassette tape. 	12 -
Humming sound is heard while playing cassette tapes.	<ul style="list-style-type: none"> • Noise from a TV. (Noise may be produced by some types of TVs.) 	<ul style="list-style-type: none"> • Move the TV away from the system. • Turn the TV off. 	5 -
Wow (shaky sound) is heavy during recording or playback.	<ul style="list-style-type: none"> • Capstans or pinch rollers are dirty. 	<ul style="list-style-type: none"> • Clean them. 	12

NIPPON COLUMBIA CO., LTD.

14-14, AKASAKA 4-CHOME, MINATO-KU, TOKYO 107-8011, JAPAN
Telephone: (03) 3584-8111

Printed in China 511 3656 003 ■ 007